

JAMES WILLIAMS

---

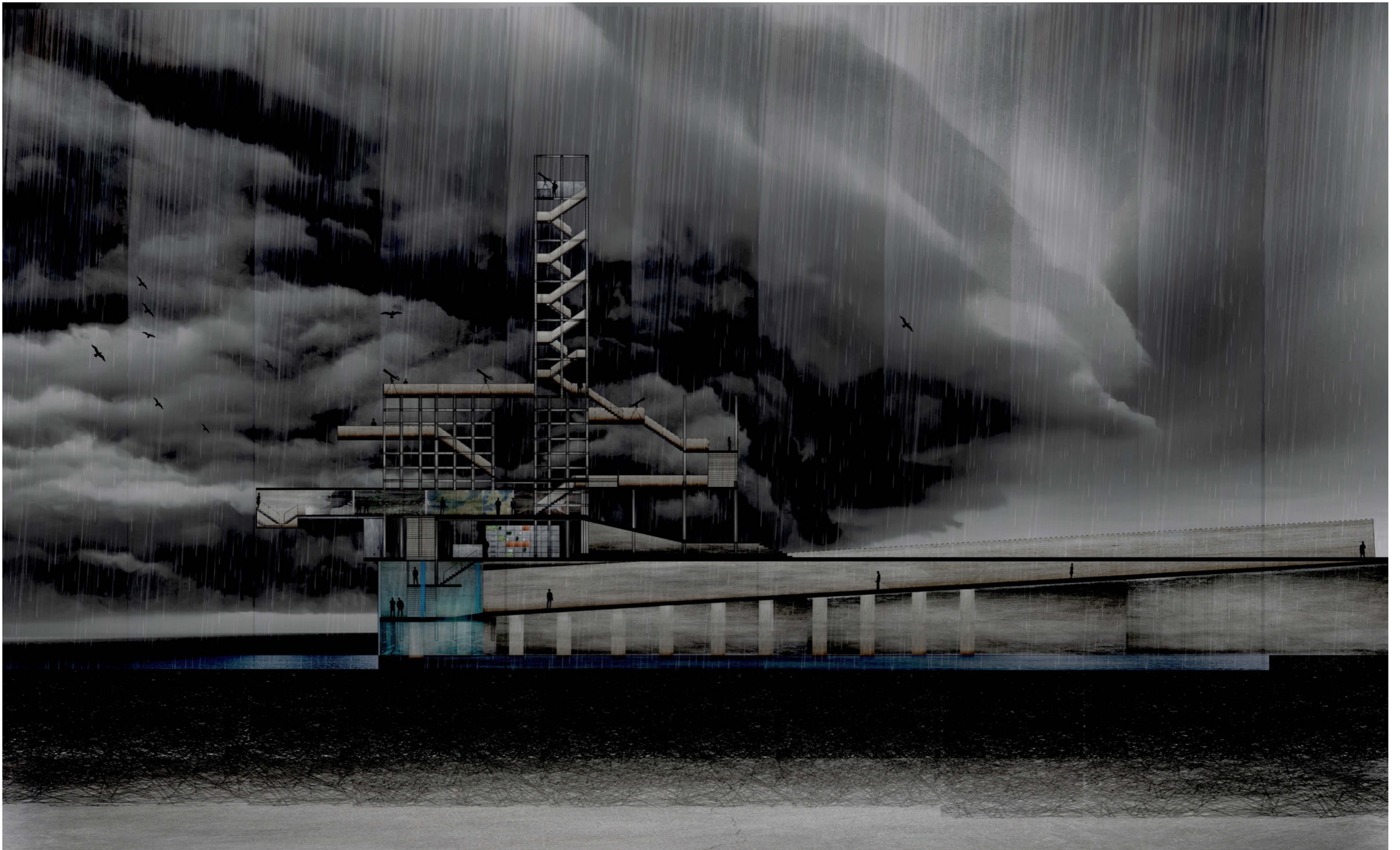

A MARITIME CONCEPT, WHITSTABLE





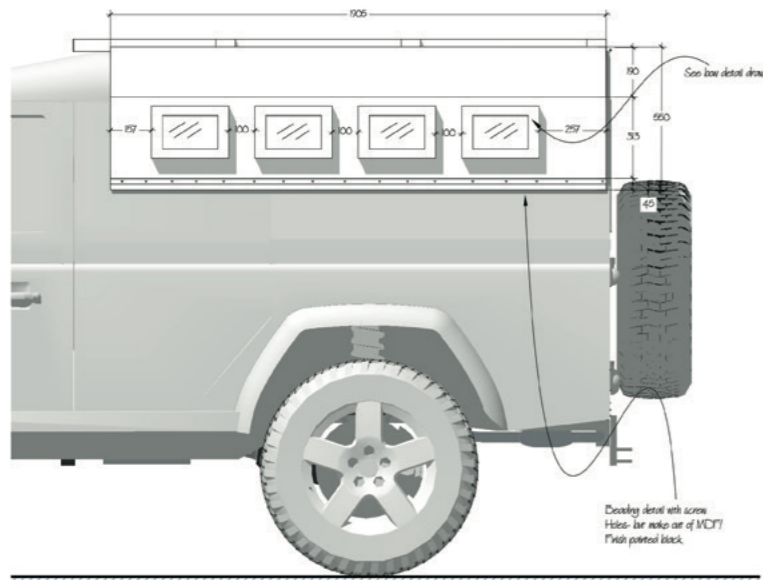

ELEVATION A - A

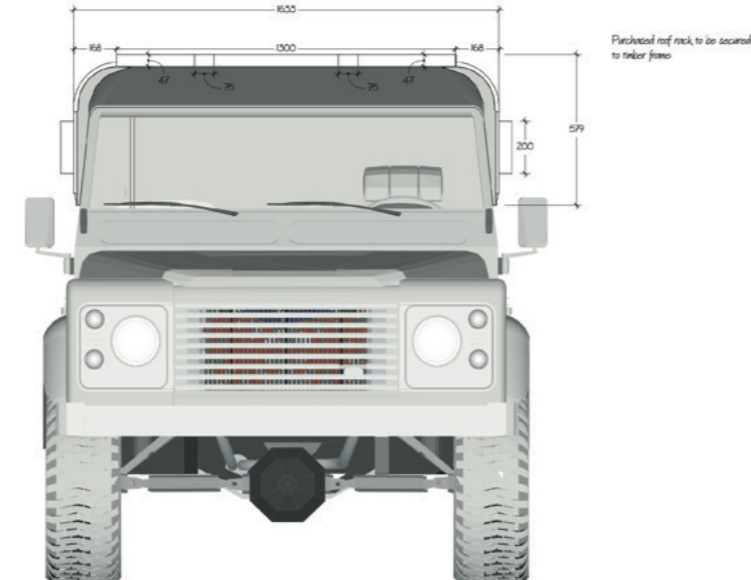

ELEVATION B - B

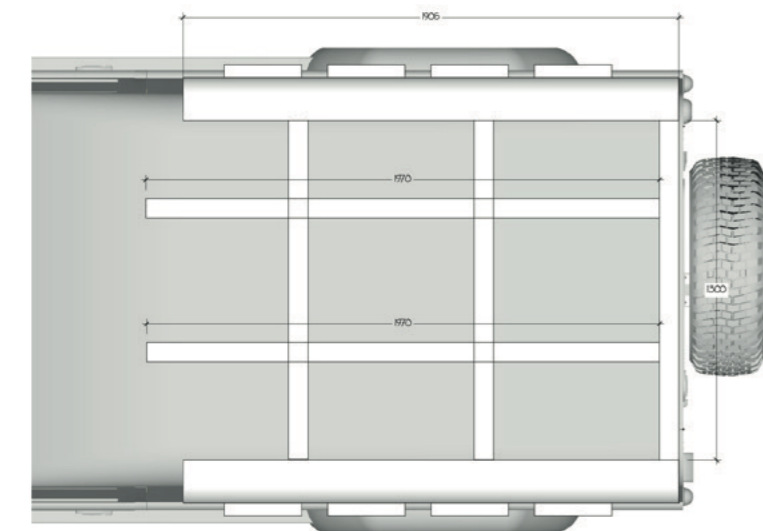

PLAN

- CONSTRUCTION NOTES**
- X 2 to be made for 2 Land Rover defenders
  - To be painted matt black, to match existing painted Land Rovers Defenders
  - Purchased Roof racks x 2 to be secured to roof timber frame
  - To be built off site in construction workshop and fitted at Motor House Hire Office

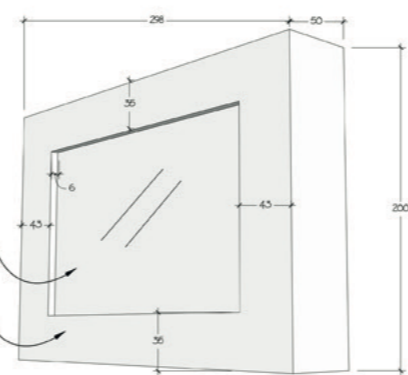

BOX WINDOW DETAIL

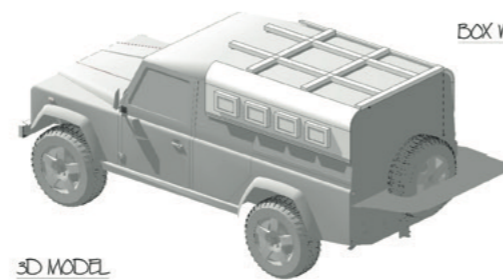

3D MODEL



REFERENCE



EXISTING LAND ROVER DEFENDER

<b>KINGDOM</b>		Set No: 136
Set Name: EXT. NORTHOLT RUNWAY		Drawing No: 001
Detail: COMPONENTS		Scale: 1:20 & 1:5 @ A1
Date Drawn:	Drawn By: James Fildes	Date Revised:
Client: [ ]	Control Manager: [ ]	Set Cost: [ ]
Production: [ ]	Company: [ ]	Props: [ ]
Technical Director: [ ]	Planner: [ ]	Prop Making: [ ]
DCP: [ ]	Plumbers: [ ]	Decor: [ ]
Principal Dept: [ ]	Signers: [ ]	Health & Safety: [ ]
Production Director: [ ]	Designers: [ ]	Special Artist: [ ]
VFX: [ ]	Metalworkers: [ ]	Signwriter: [ ]
Cost: [ ]	Graphics: [ ]	Costume: [ ]
Production Designer Approval:		

SHOOT DAY







MAKE X 1 OF

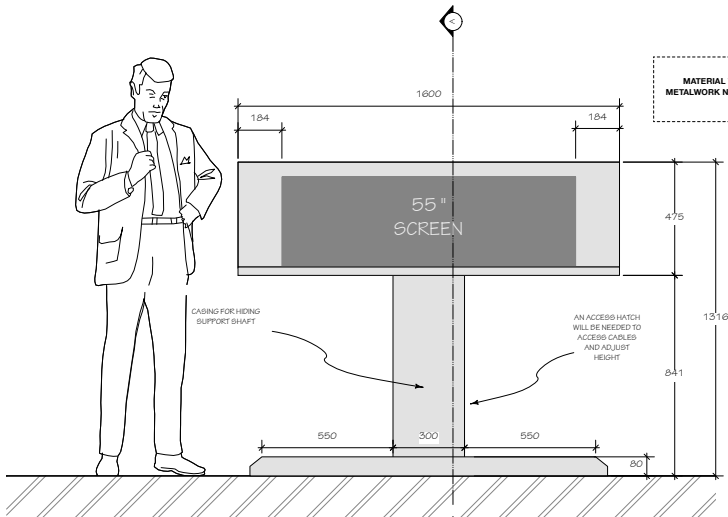

FRONT ELEVATION  
 SCALE 1:10

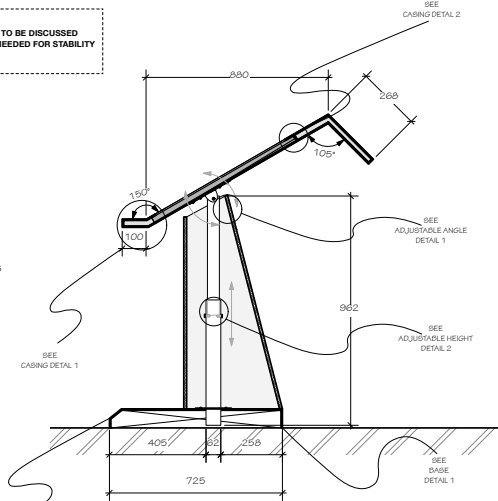

SECTION A - A  
 SCALE 1:10

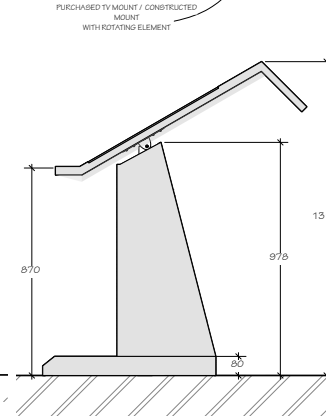

SIDE ELEVATION  
 SCALE 1:10

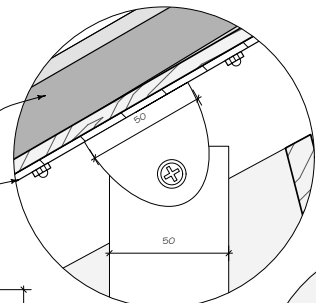

ADJUSTABLE ANGLE DETAIL 1  
 SCALE 1:1

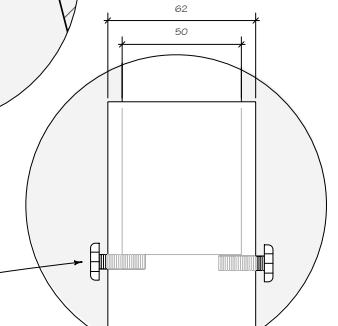

ADJUSTABLE HEIGHT DETAIL 2  
 SCALE 1:1

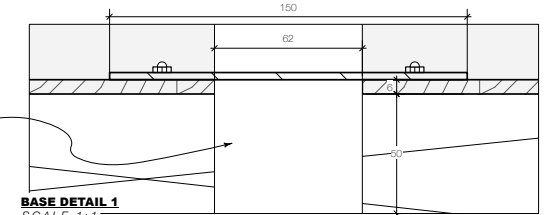

BASE DETAIL 1  
 SCALE 1:1

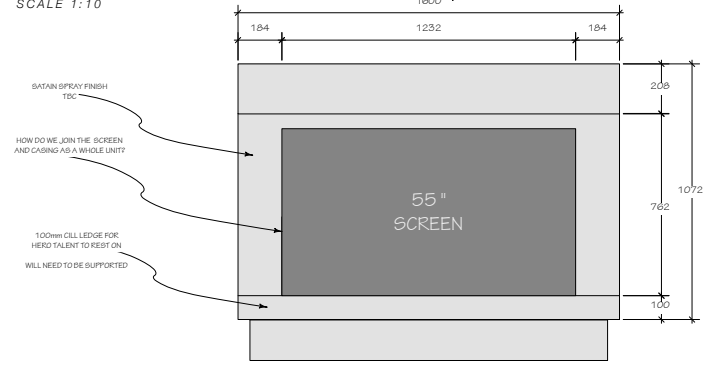

PLAN VIEW  
 SCALE 1:10

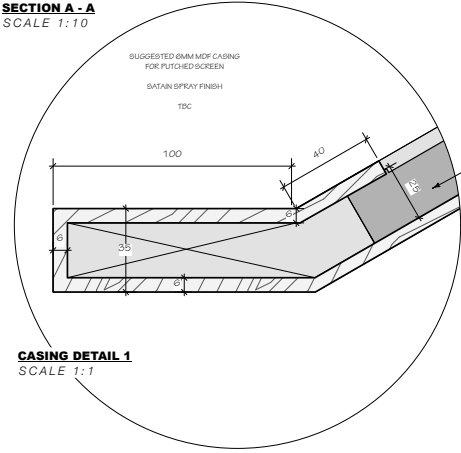

CASING DETAIL 1  
 SCALE 1:1

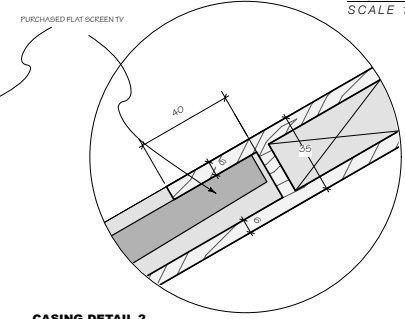

CASING DETAIL 2  
 SCALE 1:1

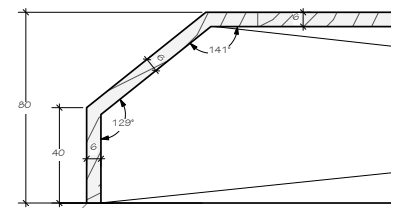

BASE DETAIL 2  
 SCALE 1:1

3D MODEL ONLY AS REF NOT FINAL DESIGN

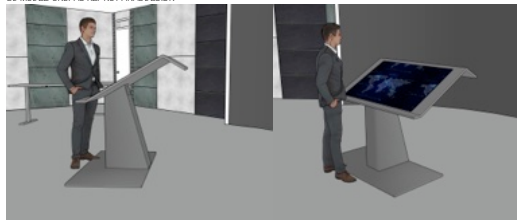

SET VISUALS



CONSTRUCTION NOTES

- WHOLE DESK TO BE CONSTRUCTED FROM MDF
- RIBBED PANEL HEIGHT 300MM (PURCHASED BY SET DEC)
- (PLUTCHED PANEL BY BAMBOO CHARACTER LK. PANELS SIZES 600mm x 2500mm)
- SATIN SPRAY FINISH FOR ALL SURFACES-INCLUDING BACK ELEVATION
- COLOUR RAL 9005
- ADDITIONAL HOLES MAY BE REQUIRED TO RUN CABLES FROM TOP TO BELOW

Production Designer: <b>CRISTINA CASALI</b>		Supervising Art Director: <b>PAZZE SPETA</b>	
Set Location: <b>IRIS 2 - GARDEN STUDIOS</b>		Scale: <b>1:10 AT ARCHD</b>	
Date: <b>20/03/25</b>		Date: <b>10/04/25</b>	
Drawn By: <b>JW</b>		Set No.: <b>008</b>	
Director	Art Department	Carpenters	X
S.O.P.	Set Dressing	Plasterers	X
Asst. Directors	Construction Managers	Painters	X
Locations	Graphics	Riggers	X
Electricians	Props	Metal Work	X
Post-Production	Inventory	S.F.X.	
Stunts	Drinks	V.F.X.	
Health & Safety	Weapons		
Approved:		Date:	
		<b>029 A</b>	

**FS PLAN SECTION THRU B - B**  
SCALE 1:10

**FRONT ELEVATION - TYPICAL PANEL**  
SCALE 1:10

**SECTION THRU PANEL A - A**  
SCALE 1:10

**FRONT ELEVATION - WINDOW PANEL**  
SCALE 1:10

**FRONT ELEVATION - FIREPLACE PANEL**  
SCALE 1:10

**CONSTRUCTION QUANTITY REQUIRED**  
MAKE 82 OF TYPICAL PANEL  
MAKE 4 OF WINDOW PANEL  
MAKE 4 OF FIREPLACE PANEL

**GRAPHICS QUANTITY REQUIRED**  
PRINT 4 OF TOP PANEL, TYPICAL 327 x 327 mm  
PRINT 82 OF PANELS PANEL, TYPICAL 327 x 400 mm  
PRINT 4 OF BOTTOM PANEL, TYPICAL 327 x 438 mm  
PRINT 4 OF WINDOW SIDE PANELS 328 x 328 mm  
PRINT 4 OF WINDOW LONG PANELS 328 x 1219 mm

**TBC ON FIREPLACE PANELS USE FIREPLACE DISTRICTS PANEL DIMENSIONS TO DISCUSS WITH AD BEFORE BEING MADE**

**AWAITING ACTUAL FIREPLACE PANELS AFTER BEING MADE**

**3D MODEL: PANNELLING FOR WINDOW**

**3D MODEL: PANNELLING FOR FIREPLACE**

**3D MODEL: PANNELLING**

**FRONT REFERENCE FOR SCENE**

**DOOR & STEP DESIGN REFERENCE**

**THE IMMORTAL MAN**

INT. THE GARRISON PUB BACK PARLOUR WALL PANEL  
SCALE: 1:10 & FS @ A0 - 841 x 1189mm  
SET: 33 DWG: NO.22

**FS SECTION THRU B - B**  
SCALE 1:1

**FS PLAN SECTION THRU A - A**  
SCALE 1:1

**FRONT ELEVATION**  
SCALE 1:10

**SECTION THRU B - B**  
SCALE 1:10

**PLAN SECTION THRU A - A**  
SCALE 1:10

**2 OF 4**  
1. EXIT PLATE DWG 04  
2. DOOR CASE DWG 05  
3. SMALL ARCHITECTURE DWG 06  
4. RED LIGHT WINDOW DWG 07

**THE IMMORTAL MAN**

ALLEY TO PIG PEN BACK EXIT  
LOC: CASTLEFIELDS, MANCHESTER  
BACK DOOR  
PLAN & SECTIONS & DETAILS  
SCALE: 1:10 & FS @ A0 1189mm x841mm  
SET: 34 DWG: NO.05

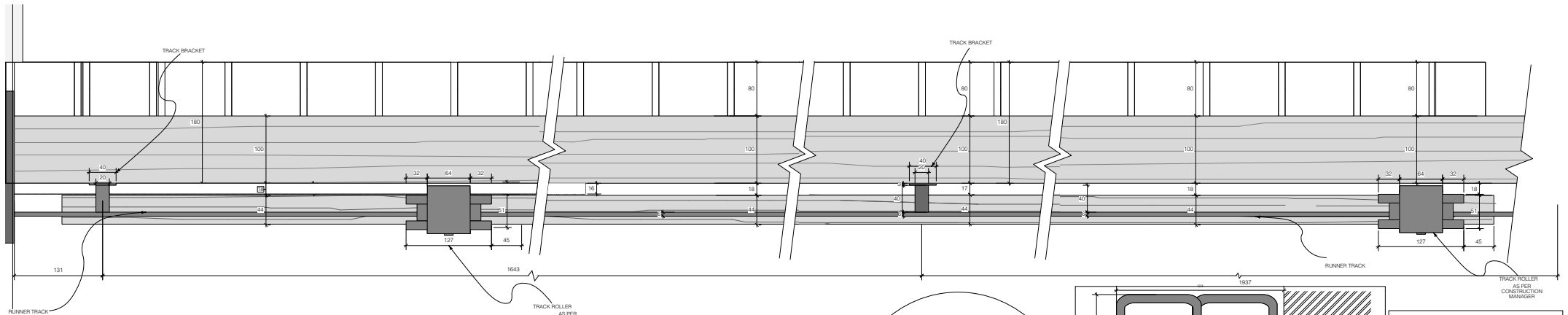

PLAN: DOOR TRACK DETAIL  
SCALE 1:2

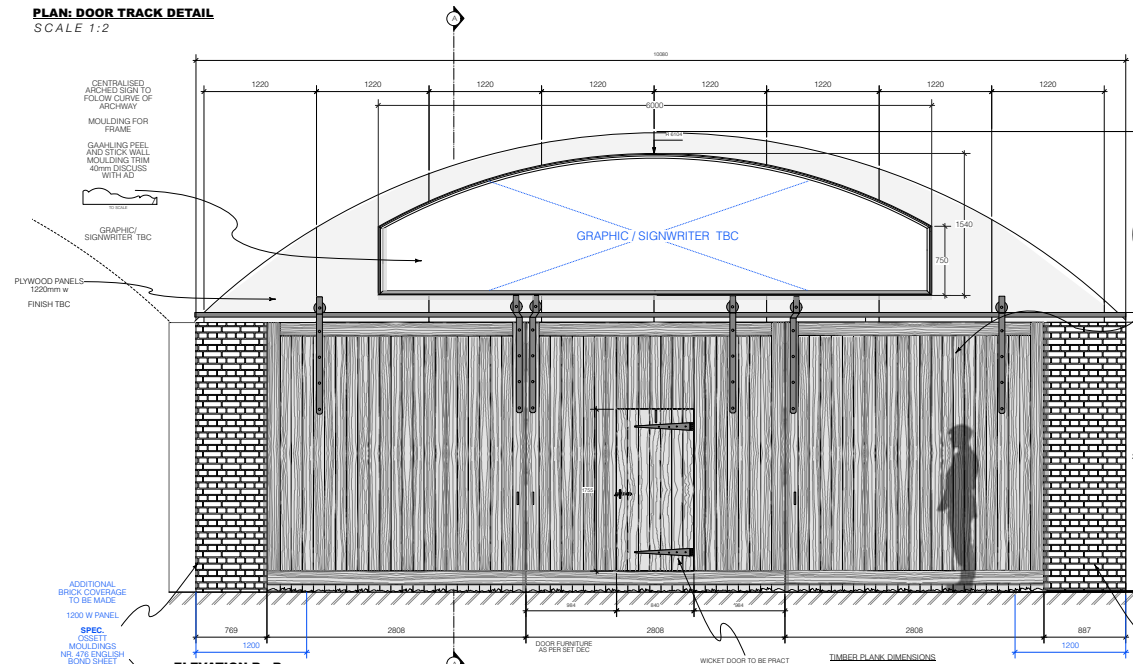

ELEVATION B - B  
SCALE 1:20

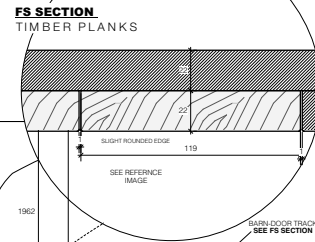

FS SECTION  
TIMBER PLANKS

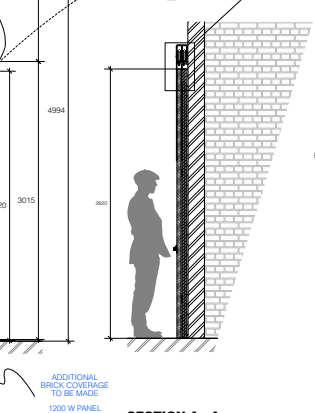

SECTION A - A  
SCALE 1:20

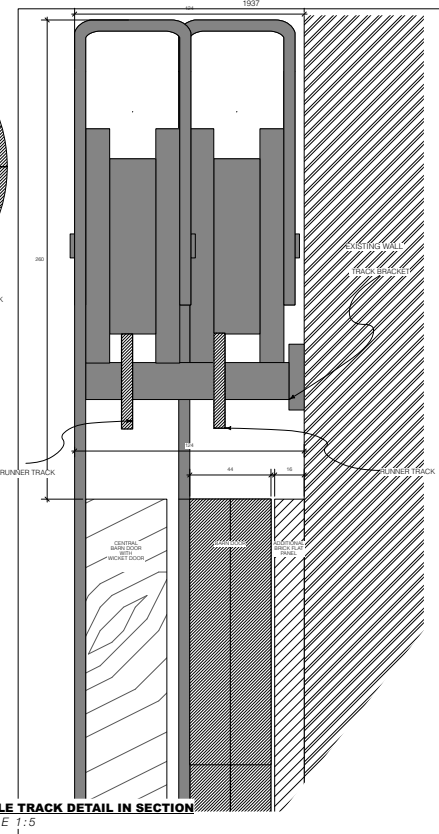

DOUBLE TRACK DETAIL IN SECTION  
SCALE 1:5

REFER TO DWG 34\_07  
BARN DOORS/BRICK WALL WHEN READING THIS DRAWING

DOOR DESIGN REFERENCE

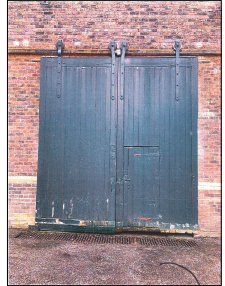

3D MODEL OF CASTLEFIELDS MANCHESTER



LOCATION

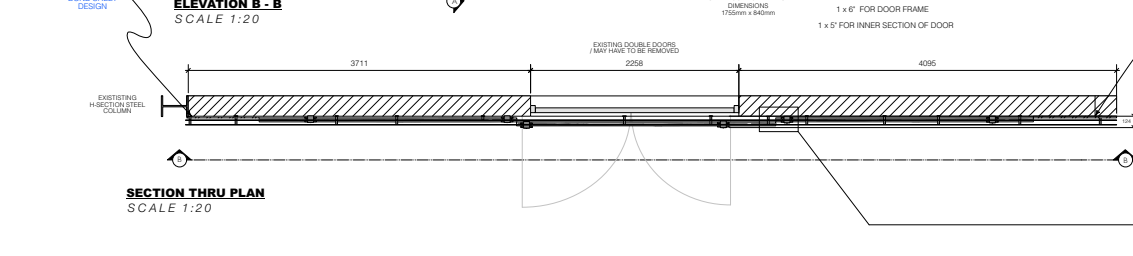
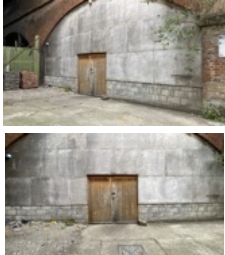

SECTION THRU PLAN  
SCALE 1:20

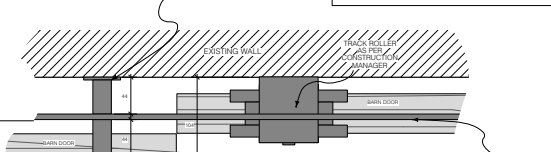

DOUBLE TRACK DETAIL IN PLAN  
SCALE 1:5

THE IMMORTAL MAN				SET NO.
REF:	EXT GARRISON PUB, GARRISON LANE	SCALE:	1:10 & FS	034
DETAILS:	LAUNDRY DOORS + WALL B	DATE DRAWN:	29/08/24	
STABILIZATION:	CASTLEFIELDS + STUDIO	DATE REVISION:		
DRAWN BY:	JAMES WILLIAMS	DESIGNER:	JACQUELINE ABRAMMS	
DIRECTOR:	TOM HARPER	PRODUCTION:		
ARCHITECT:	CASTLEFIELDS + STUDIO	CLIENT:	THE IMMORTAL MAN	
CONTRACTOR:		MANAGER:		
STRUCTURAL:		ENGINEER:		
MECHANICAL:		ELECTRICAL:		
PLUMBING:		PAINTING:		
LANDSCAPE:		SCULPTURE:		
INTERIOR:		SALES:		
EXTERIOR:		MARKETING:		
FINISHES:		LOGISTICS:		
INSTALLATION:		OPERATIONS:		
MAINTENANCE:		TRAINING:		
OPERATIONS:		SAFETY:		
COMPLETION:		QUALITY:		
START:		FINISH:		
END:		STATUS:		
DATE:		BY:		
TIME:		NO:		
SCALE:		REV:		
PROJECT:		APP:		
NO:		DATE:		
DATE:		BY:		
TIME:		NO:		
SCALE:		REV:		
PROJECT:		APP:		
NO:		DATE:		
DATE:		BY:		
TIME:		NO:		
SCALE:		REV:		
PROJECT:		APP:		
NO:		DATE:		
DATE:		BY:		
TIME:		NO:		
SCALE:		REV:		
PROJECT:		APP:		
NO:		DATE:		
DATE:		BY:		
TIME:		NO:		
SCALE:		REV:		
PROJECT:		APP:		
NO:		DATE:		
DATE:		BY:		
TIME:		NO:		
SCALE:		REV:		
PROJECT:		APP:		
NO:		DATE:		
DATE:		BY:		
TIME:		NO:		
SCALE:		REV:		
PROJECT:		APP:		
NO:		DATE:		
DATE:		BY:		
TIME:		NO:		
SCALE:		REV:		
PROJECT:		APP:		
NO:		DATE:		
DATE:		BY:		
TIME:		NO:		
SCALE:		REV:		
PROJECT:		APP:		
NO:		DATE:		
DATE:		BY:		
TIME:		NO:		
SCALE:		REV:		
PROJECT:		APP:		
NO:		DATE:		
DATE:		BY:		
TIME:		NO:		
SCALE:		REV:		
PROJECT:		APP:		
NO:		DATE:		
DATE:		BY:		
TIME:		NO:		
SCALE:		REV:		
PROJECT:		APP:		
NO:		DATE:		
DATE:		BY:		
TIME:		NO:		
SCALE:		REV:		
PROJECT:		APP:		
NO:		DATE:		
DATE:		BY:		
TIME:		NO:		
SCALE:		REV:		
PROJECT:		APP:		
NO:		DATE:		
DATE:		BY:		
TIME:		NO:		
SCALE:		REV:		
PROJECT:		APP:		
NO:		DATE:		
DATE:		BY:		
TIME:		NO:		
SCALE:		REV:		
PROJECT:		APP:		
NO:		DATE:		
DATE:		BY:		
TIME:		NO:		
SCALE:		REV:		
PROJECT:		APP:		
NO:		DATE:		
DATE:		BY:		
TIME:		NO:		
SCALE:		REV:		
PROJECT:		APP:		
NO:		DATE:		
DATE:		BY:		
TIME:		NO:		
SCALE:		REV:		
PROJECT:		APP:		
NO:		DATE:		
DATE:		BY:		
TIME:		NO:		
SCALE:		REV:		
PROJECT:		APP:		
NO:		DATE:		
DATE:		BY:		
TIME:		NO:		
SCALE:		REV:		
PROJECT:		APP:		
NO:		DATE:		
DATE:		BY:		
TIME:		NO:		
SCALE:		REV:		
PROJECT:		APP:		
NO:		DATE:		
DATE:		BY:		
TIME:		NO:		
SCALE:		REV:		
PROJECT:		APP:		
NO:		DATE:		
DATE:		BY:		
TIME:		NO:		
SCALE:		REV:		
PROJECT:		APP:		
NO:		DATE:		
DATE:		BY:		
TIME:		NO:		
SCALE:		REV:		
PROJECT:		APP:		
NO:		DATE:		
DATE:		BY:		
TIME:		NO:		
SCALE:		REV:		
PROJECT:		APP:		
NO:		DATE:		
DATE:		BY:		
TIME:		NO:		
SCALE:		REV:		
PROJECT:		APP:		
NO:		DATE:		
DATE:		BY:		
TIME:		NO:		
SCALE:		REV:		
PROJECT:		APP:		
NO:		DATE:		
DATE:		BY:		
TIME:		NO:		
SCALE:		REV:		
PROJECT:		APP:		
NO:		DATE:		
DATE:		BY:		
TIME:		NO:		
SCALE:		REV:		
PROJECT:		APP:		
NO:		DATE:		
DATE:		BY:		
TIME:		NO:		
SCALE:		REV:		
PROJECT:		APP:		
NO:		DATE:		
DATE:		BY:		
TIME:		NO:		
SCALE:		REV:		
PROJECT:		APP:		
NO:		DATE:		
DATE:		BY:		
TIME:		NO:		
SCALE:		REV:		
PROJECT:		APP:		
NO:		DATE:		
DATE:		BY:		
TIME:		NO:		
SCALE:		REV:		
PROJECT:		APP:		
NO:		DATE:		
DATE:		BY:		
TIME:		NO:		
SCALE:		REV:		
PROJECT:		APP:		
NO:		DATE:		
DATE:		BY:		
TIME:		NO:		
SCALE:		REV:		
PROJECT:		APP:		
NO:		DATE:		
DATE:		BY:		
TIME:		NO:		
SCALE:		REV:		
PROJECT:		APP:		
NO:		DATE:		
DATE:		BY:		
TIME:		NO:		
SCALE:		REV:		
PROJECT:		APP:		
NO:		DATE:		
DATE:		BY:		
TIME:		NO:		
SCALE:		REV:		
PROJECT:		APP:		
NO:		DATE:		
DATE:		BY:		
TIME:		NO:		
SCALE:		REV:		
PROJECT:		APP:		
NO:		DATE:		
DATE:		BY:		
TIME:		NO:		
SCALE:		REV:		
PROJECT:		APP:		
NO:		DATE:		
DATE:		BY:		
TIME:		NO:		
SCALE:		REV:		
PROJECT:		APP:		
NO:		DATE:		
DATE:		BY:		
TIME:		NO:		
SCALE:		REV:		
PROJECT:		APP:		
NO:		DATE:		
DATE:		BY:		
TIME:		NO:		
SCALE:		REV:		
PROJECT:		APP:		
NO:		DATE:		
DATE:		BY:		
TIME:		NO:		
SCALE:		REV:		
PROJECT:		APP:		
NO:		DATE:		
DATE:		BY:		
TIME:		NO:		
SCALE:		REV:		
PROJECT:		APP:		
NO:		DATE:		
DATE:		BY:		
TIME:		NO:		
SCALE:		REV:		
PROJECT:		APP:		
NO:		DATE:		
DATE:		BY:		
TIME:		NO:		
SCALE:		REV:		
PROJECT:		APP:		
NO:		DATE:		
DATE:		BY:		
TIME:		NO:		
SCALE:		REV:		
PROJECT:		APP:		
NO:		DATE:		
DATE:		BY:		
TIME:		NO:		
SCALE:		REV:		
PROJECT:		APP:		
NO:		DATE:		
DATE:		BY:		
TIME:		NO:		
SCALE:		REV:		
PROJECT:		APP:		
NO:		DATE:		
DATE:		BY:		
TIME:		NO:		
SCALE:		REV:		
PROJECT:		APP:		
NO:		DATE:		
DATE:		BY:		
TIME:		NO:		
SCALE:		REV:		
PROJECT:		APP:		
NO:		DATE:		

MAKE X 2 OFF  
ELEVATIONS A, B, C

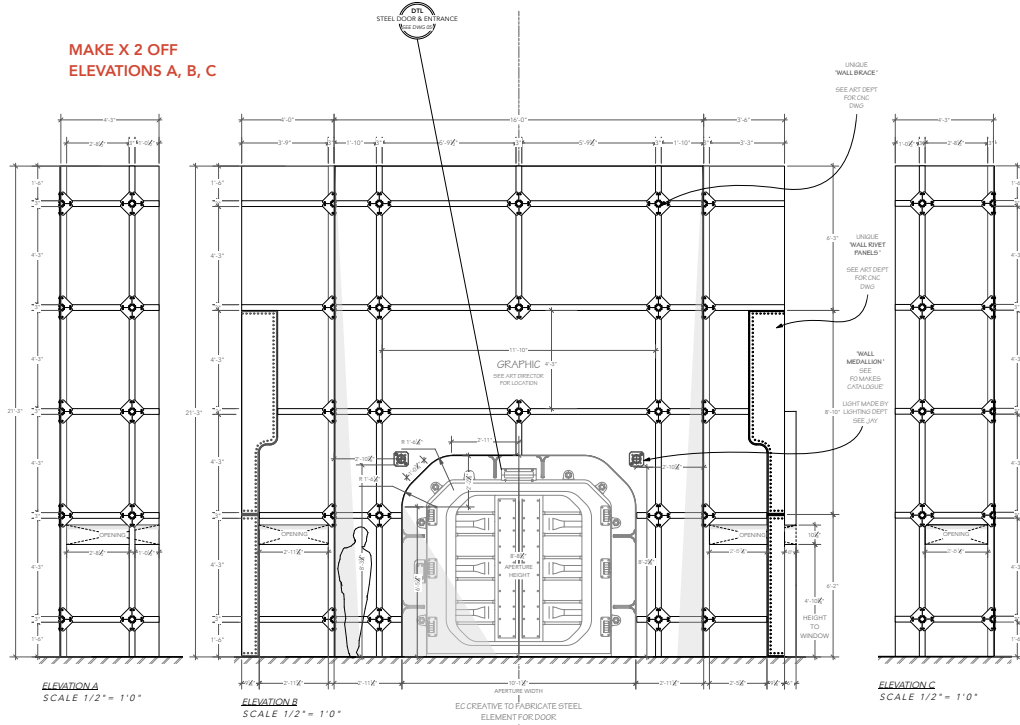

MAKE X 2 OFF  
ELEVATIONS D, E, F

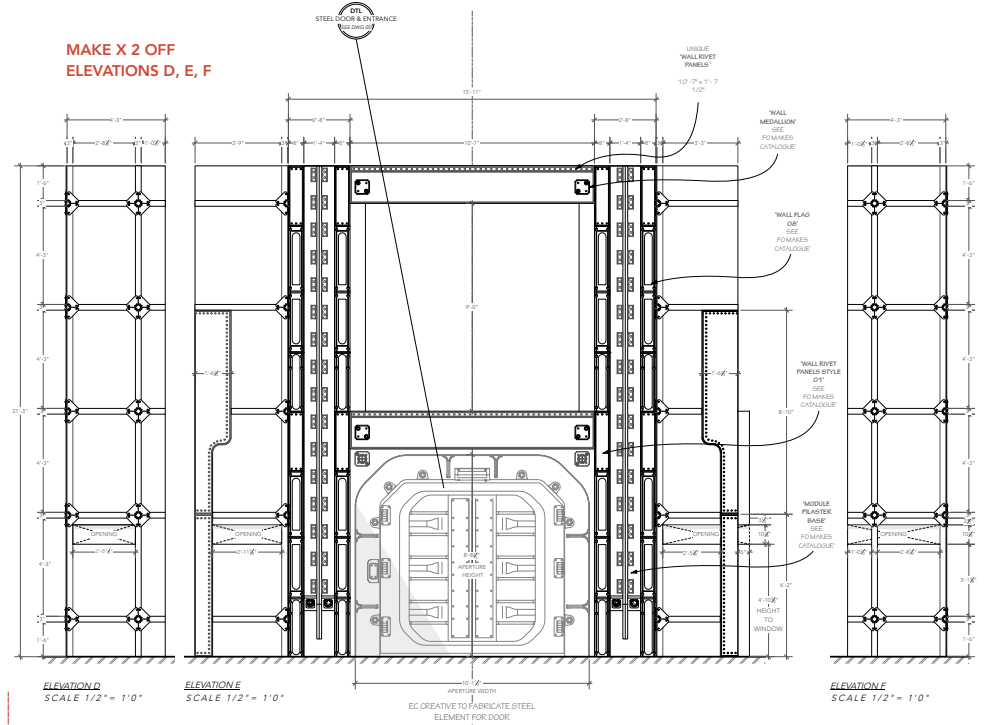

PLEASE NOTE  
FLATTAGE IS MIRRORED  
TO MAKE X2 OFF ELEVATIONS

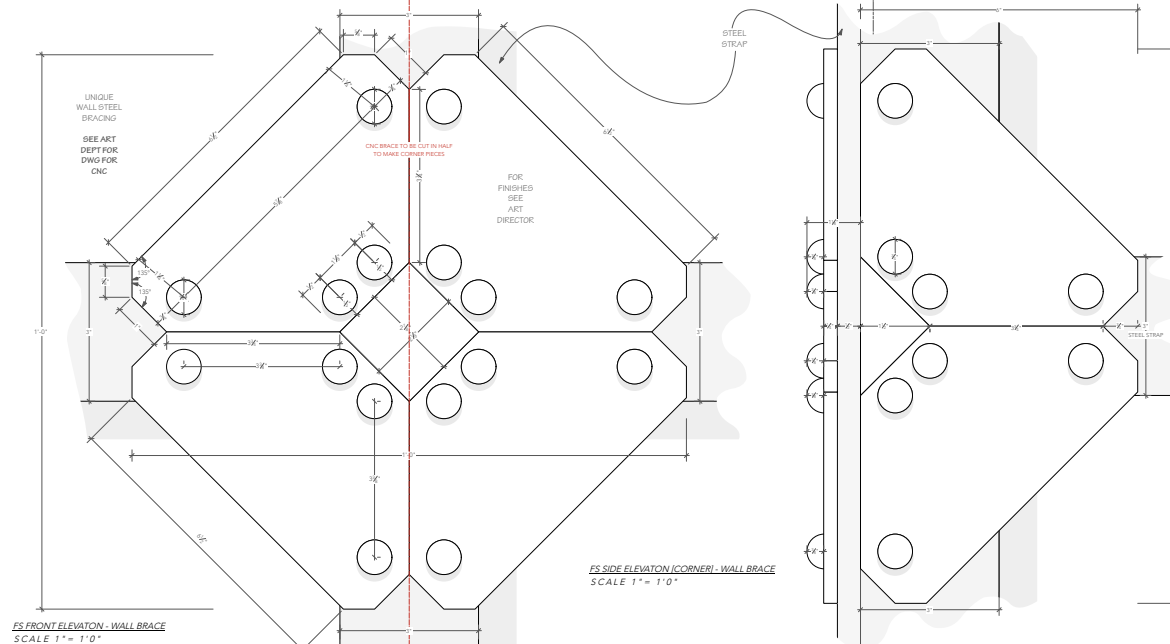
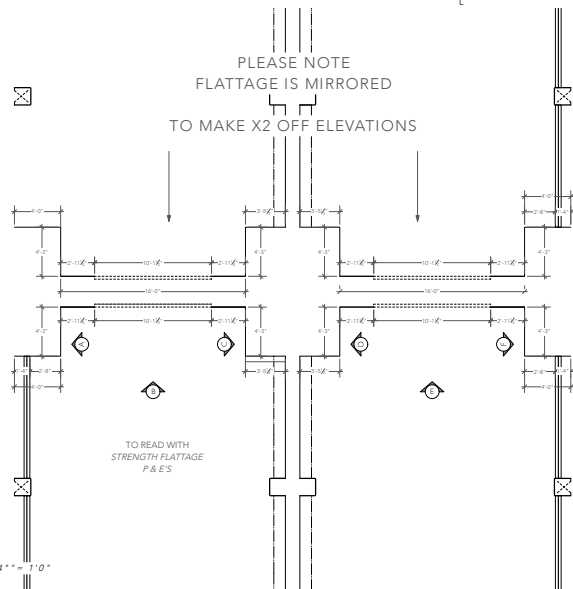

**COMPONENT LIST (SEE MAKES CATALOGUE)**

- MAKES
- X4 OFF UNIQUE "WALL RIVET PANELS"
  - X8 OFF "WALL MEDALLION"
  - X8 OFF "WALL FLAG 08"
  - X8 OFF "WALL RIVET PANELS STYLE 07"
  - X4 OFF "MODULE PLASTER BASE"
  - X8 OFF UNIQUE CURVED "WALL RIVET PANELS"
  - X105 OFF "WALL BRACES"

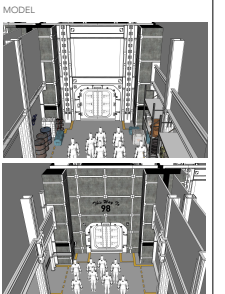

<b>FALLOUT</b>		ART DIRECTOR: [Name]
Project Name	Version	Date
Revision Number	Revised By	Revised Date
Drawn By	Checked By	Scale
Sheet No.	Total Sheets	Project No.

**bizibot**

MAKE X 2 OFF - DOUBLE SIDED

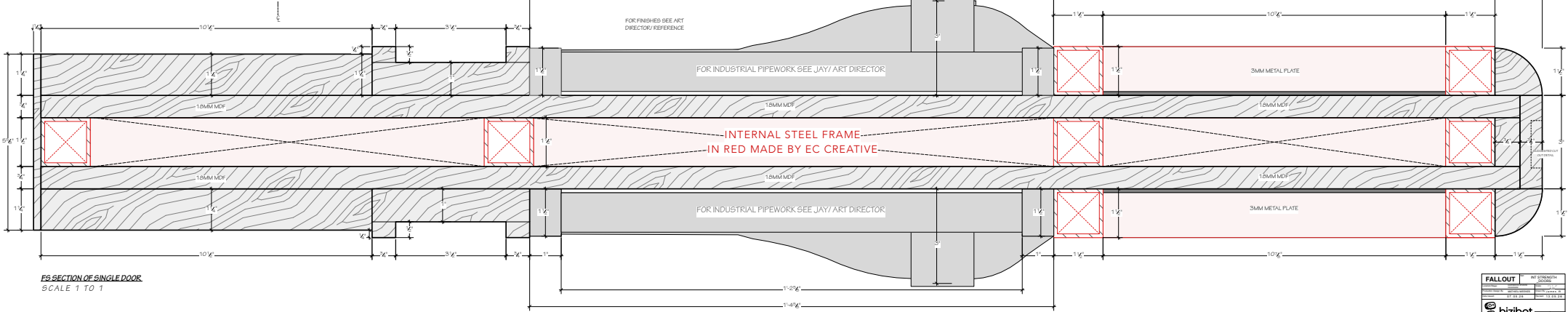
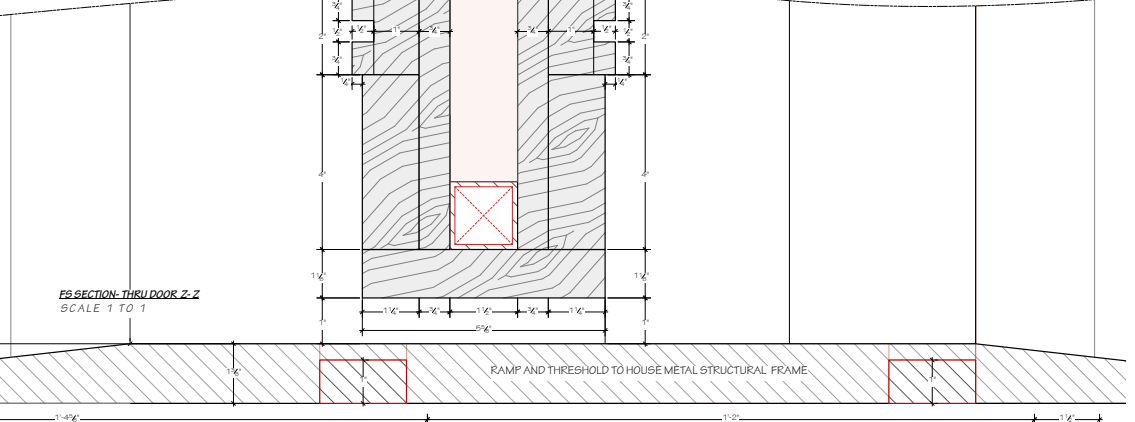
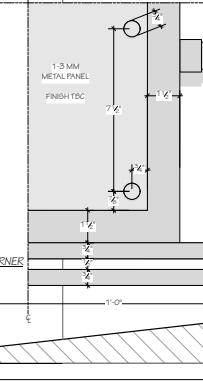
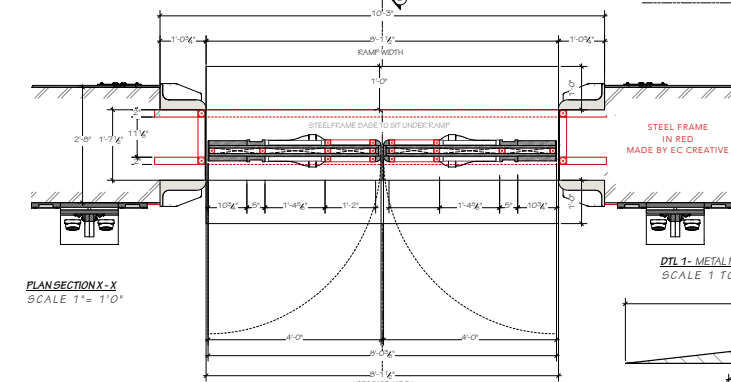
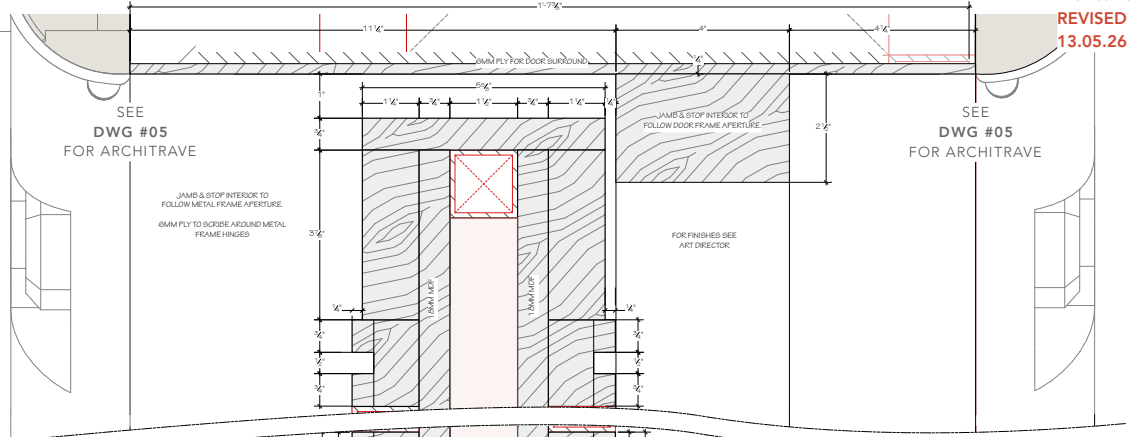
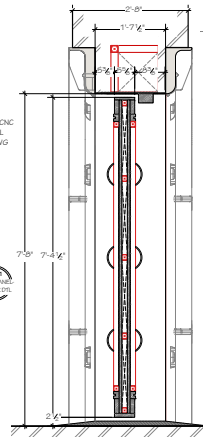
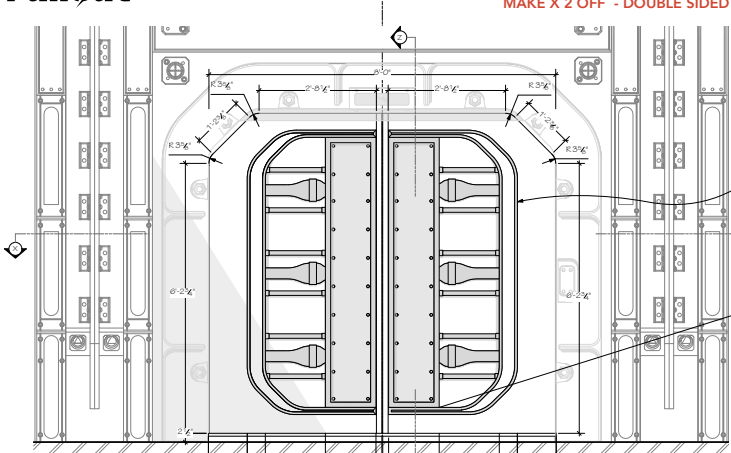



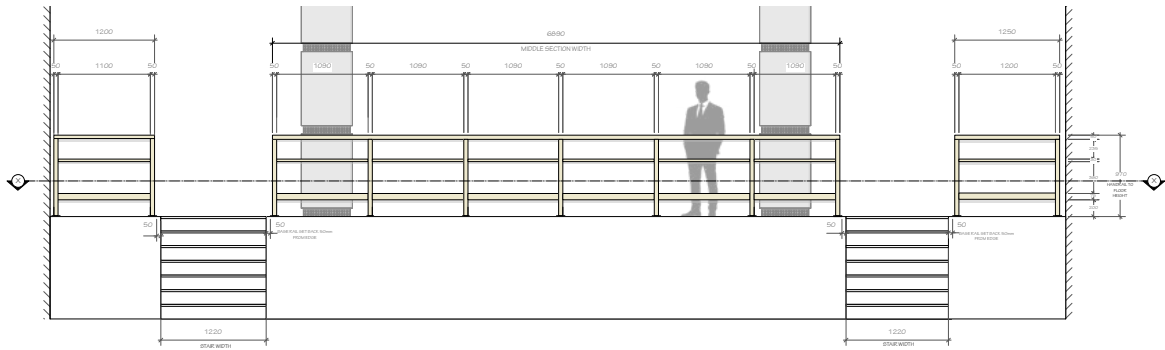

**FRONT ELEVATION - VIP BAR RAILING**  
SCALE 1:20

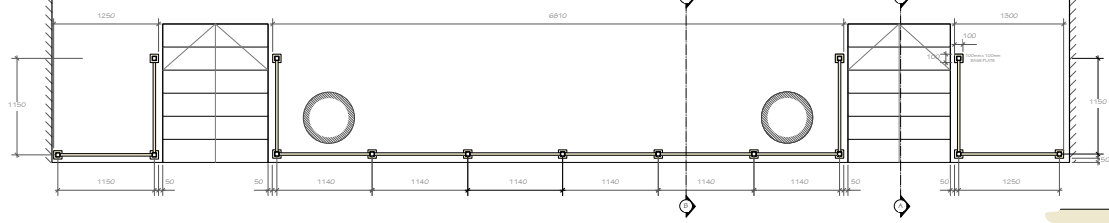

**PLAN SECTION - X - X**  
SCALE 1:20

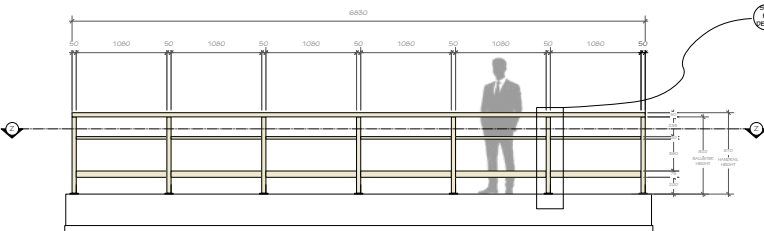

**FRONT ELEVATION - BALCONY**  
SCALE 1:20

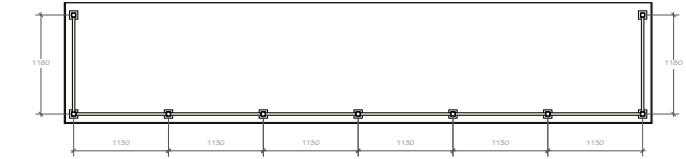

**PLAN SECTION Z - Z**  
SCALE 1:20

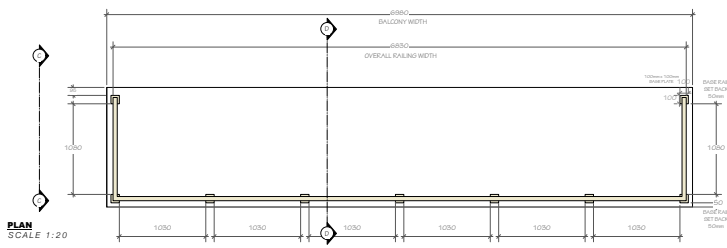

**PLAN**  
SCALE 1:20

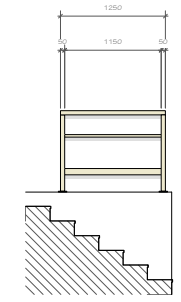

**SECTION A - A**  
SCALE 1:20

**SECTION B - B**  
SCALE 1:20

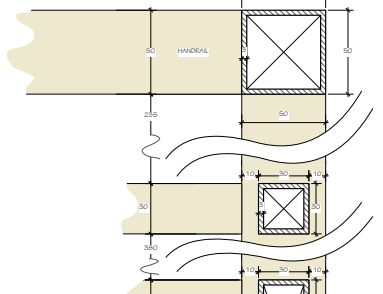

**ELEVATION C - C**  
SCALE 1:20

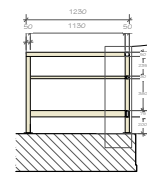

**SECTION D - D**  
SCALE 1:20

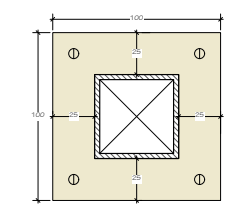

**BASE PLATE DETAIL**  
SCALE 1:1

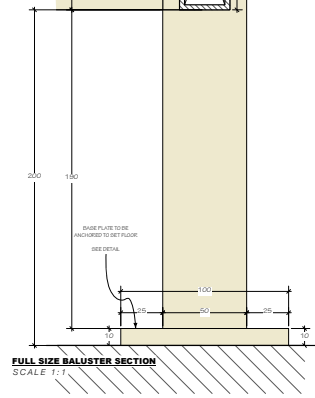

**FULL SIZE BALUSTER SECTION**  
SCALE 1:1

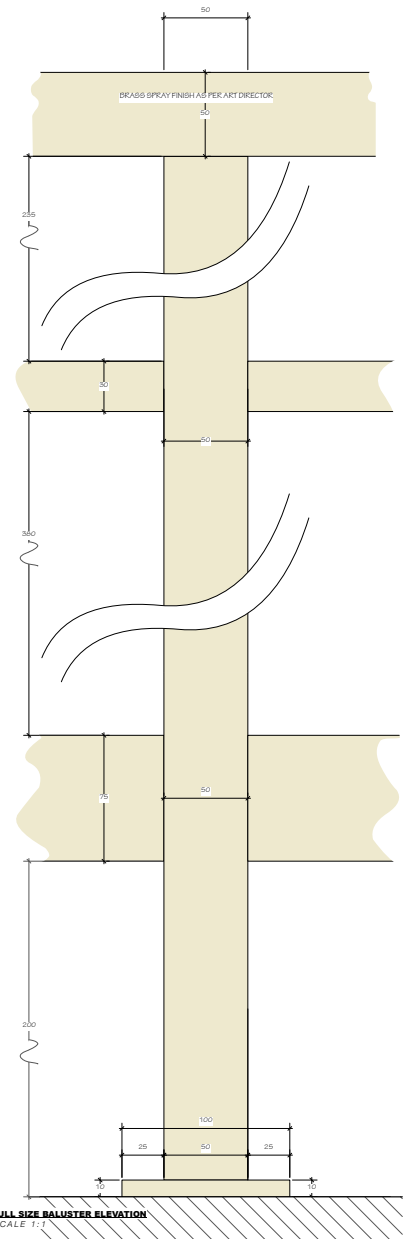

**FULL SIZE BALUSTER ELEVATION**  
SCALE 1:1

**NOTES:**  
- FOR POSITIONING IN SET READ WITH DWG 005/001  
- INT. BLUE MOUNTAIN CASINO - RAILING SECTIONS & ELEVATIONS  
- TO BE FABRICATED USING BOX HOLLOW STEEL - USING STANDARD OFF THE SHELF SIZES  
- BRASS PAINTED FINISH - TO DISCUSS WITH ART DIRECTOR

FIGHTLAND		DRAWING	
PROJECT	INT. BLUE MOUNTAIN CASINO	SET	003
DRAWING	RAILING DRAWINGS	NO.	006
DATE	08.08.25	SCALE	1:20
DESIGNED BY	STAGE 5 EASTBROOK STUDIOS	CHECKED BY	ART & DESIGN

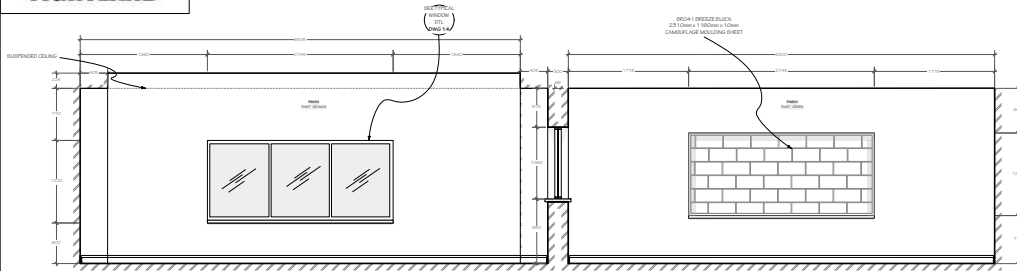

SECTION A-A  
SCALE 1:20

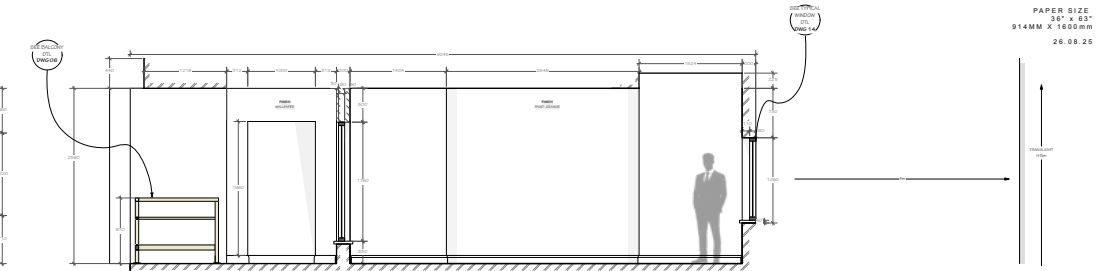

SECTION C-C  
SCALE 1:20

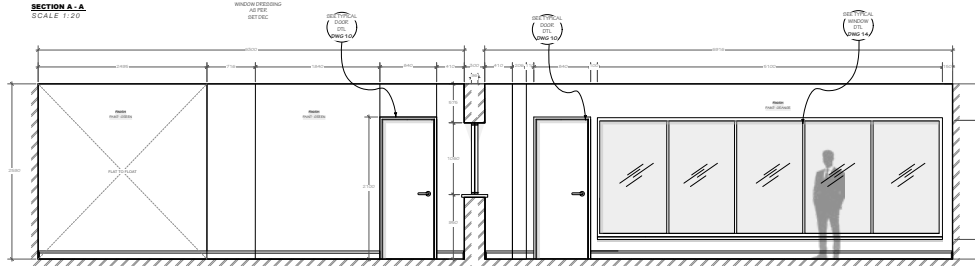

SECTION B-B  
SCALE 1:20

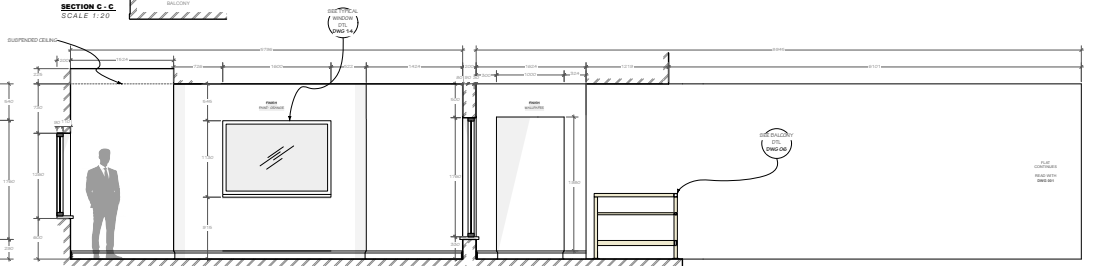

SECTION D-D  
SCALE 1:20

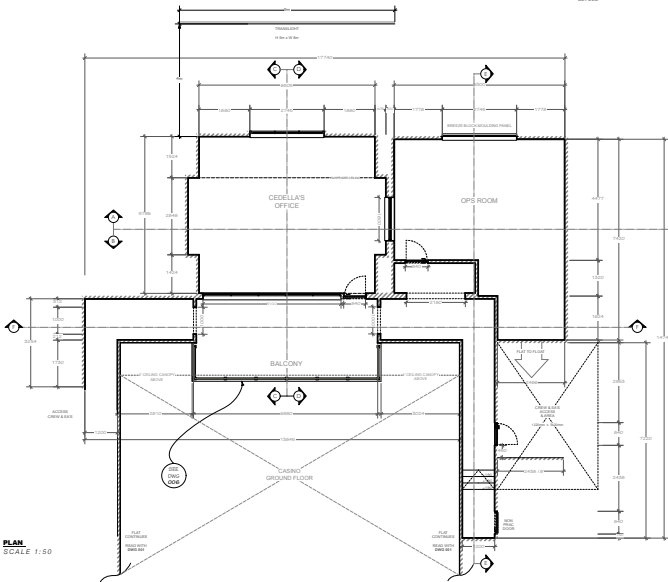

PLAN  
SCALE 1:50

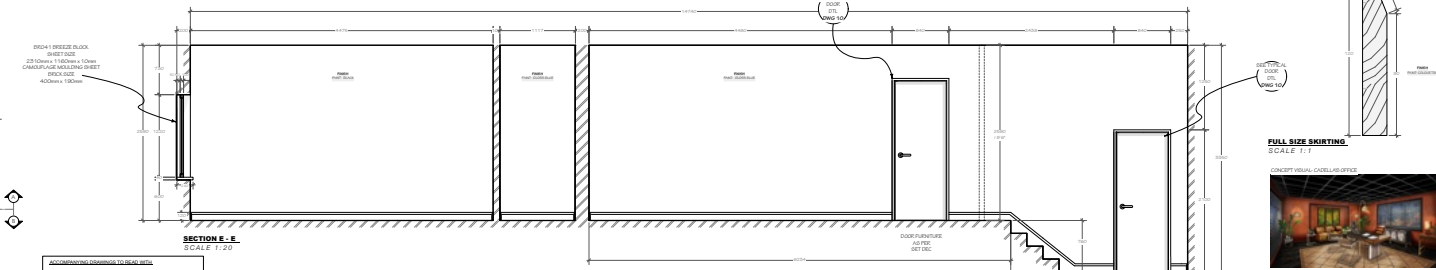

SECTION E-E  
SCALE 1:20

ACCOMMODATION REQUIREMENTS TO BE MET:  
- ALL ROOMS MUST BE MET BY BLUE MOUNTAIN CASINO PLANS, SECTIONS & ELEVATIONS  
- DOOR: ALL DOORS MUST BE MET BY BLUE MOUNTAIN CASINO PLANS, SECTIONS & ELEVATIONS  
- WINDOW: ALL WINDOWS MUST BE MET BY BLUE MOUNTAIN CASINO PLANS, SECTIONS & ELEVATIONS  
- BALCONY: ALL BALCONIES MUST BE MET BY BLUE MOUNTAIN CASINO PLANS, SECTIONS & ELEVATIONS

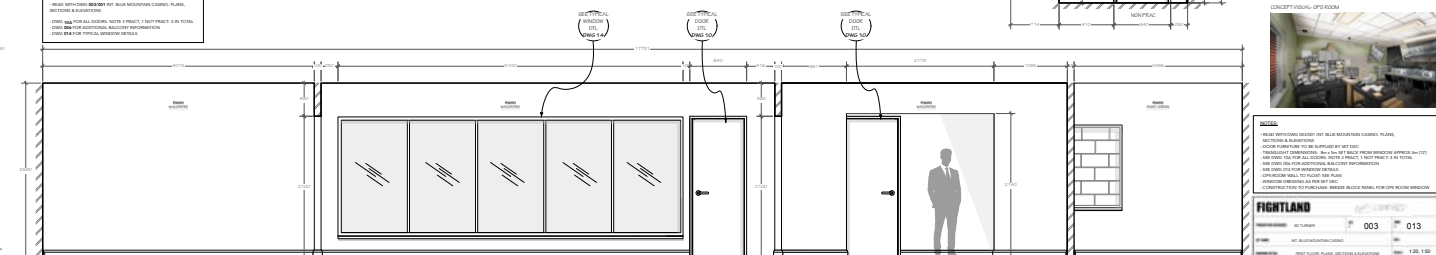

SECTION F-F  
SCALE 1:20

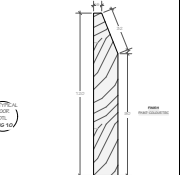

FULL SIZE SKIRTING  
SCALE 1:1



**NOTES**

- ALL WORK TO BE DONE BY BLUE MOUNTAIN CASINO PLANS, SECTIONS & ELEVATIONS
- DOOR: ALL DOORS MUST BE MET BY BLUE MOUNTAIN CASINO PLANS, SECTIONS & ELEVATIONS
- WINDOW: ALL WINDOWS MUST BE MET BY BLUE MOUNTAIN CASINO PLANS, SECTIONS & ELEVATIONS
- BALCONY: ALL BALCONIES MUST BE MET BY BLUE MOUNTAIN CASINO PLANS, SECTIONS & ELEVATIONS

**FIGHTLAND**

PROJECT	INT. BLUE MOUNTAIN CASINO EASTBROOK STUDIOS- STAGE 5
DATE	28.08.25
SCALE	1:50, 1:20 & FULL SIZE
DWG NO.	003_013
DESIGNED BY	ENR & EASTBROOK STUDIOS

